

RIGHT ANGLE PLUG CRIMP TYPE

R120.173.500

CABLE 2/50 S

Series : DIN 41626

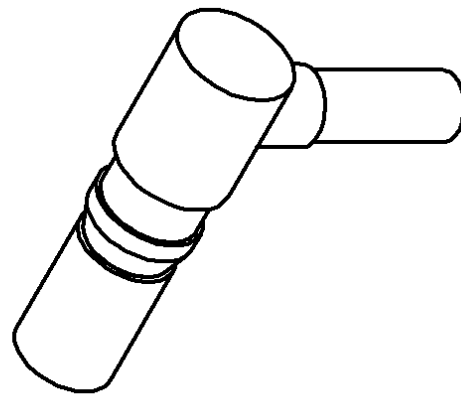
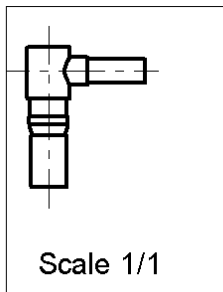
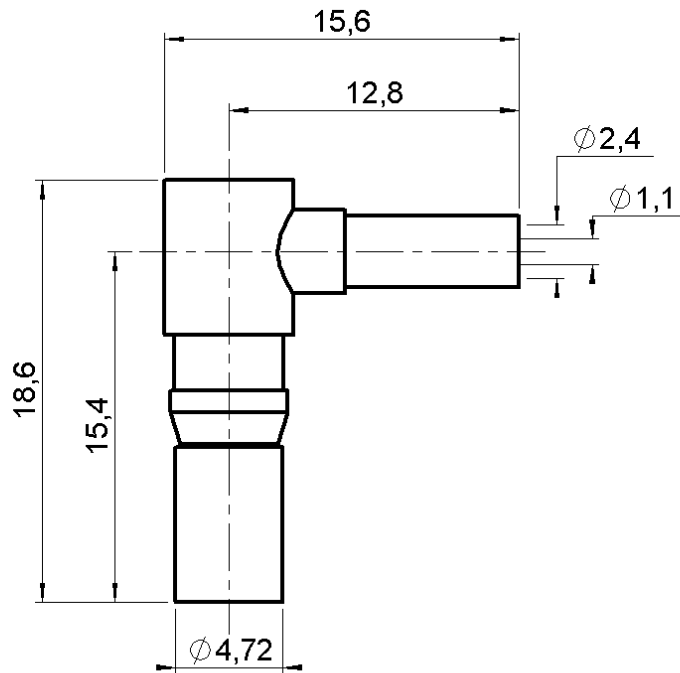

All dimensions are in mm.

COMPONENTS	MATERIALS	PLATINGS (μm)
BODY	BRASS	GOLD .
CENTER CONTACT	BRASS	GOLD .
OUTER CONTACT	BERYLLIUM COPPER	GOLD .
INSULATOR	PTFE	
GASKET	-	-
OTHERS PARTS	-	-
-	-	-
-	-	-

Issue : 0048 B

In the effort to improve our products, we reserve the right to make changes judged to be necessary.



RIGHT ANGLE PLUG CRIMP TYPE

R120.173.500

CABLE 2/50 S

Series : **DIN 41626**

PACKAGING

Standard	Unit	Other
100	'W' option	Contact us

SPECIFICATION

ELECTRICAL CHARACTERISTICS

Impedance		50 Ω
Frequency		0-2 GHz
VSWR	1.40 +	0.000 x F(GHz) Maxi
Insertion loss		NA √F(GHz) dB Maxi
RF leakage	- (NA - F(GHz)) dB Maxi
Voltage rating		250 Veff Maxi
Dielectric withstanding voltage		750 Veff mini
Insulation resistance		1000 MΩ mini

CABLE ASSEMBLY

Stripping	a	b	c	d	e	f
mm	1.00	7.00	12.0	0.00	11.0	0.00

Assembly instruction :

Recommended cable(s)
 RG 178
 RG 196
 RG 178 LC
 KX 21

MECHANICAL CHARACTERISTICS

Center contact retention		
Axial force – Mating end	10	N mini
Axial force – Opposite end	10	N mini
Torque	NA	N.cm mini

Cable retention

- pull off	40	N mini
- torque	NA	N.cm

TOOLING

Part Number	Description	Hexagon
.	.	.
R282.235.003	CRIMPING DIES	2.67
R282.293.000	CRIMPING TOOL	-
R282.211.000	CRIMPING TOOL	2.67

Recommended torque		
Mating	NA	N.cm
Panel nut	NA	N.cm
Clamp nut	NA	N.cm
A/F clamp nut	0.000	mm

Mating life	100	Cycles mini
Weight	2.240	g

OTHERS CHARACTERISTICS

ENVIRONMENTAL

Operating temperature	-55/+155	° C
Hermetic seal	NA	Atm.cm3/s
Panel leakage	NA	

Issue : **0048 B**

In the effort to improve our products, we reserve the right to make changes judged to be necessary.



RIGHT ANGLE PLUG CRIMP TYPE

R120.173.500

CABLE 2/50 S

Series : DIN 41626

COMPONENTS

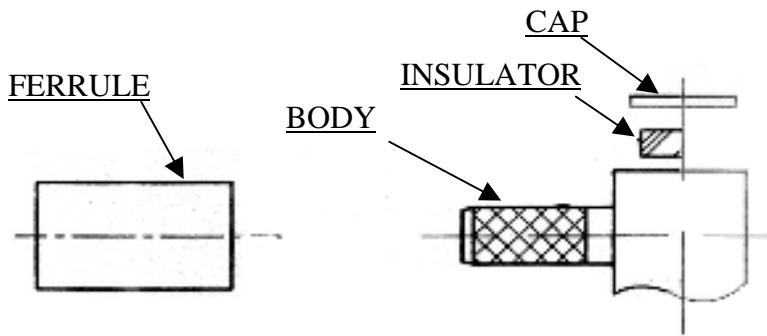

STRIPPING DIMENSIONS

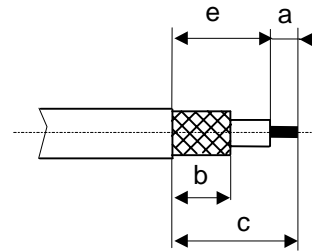

1

- Slide the ferrule onto the cable.
- Strip the cable .

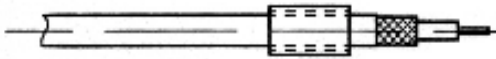

3

- Crimp the ferrule with crimping tool .
- Solder inner conductor.

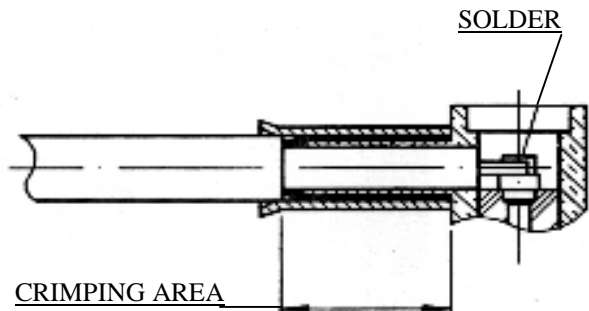

2

- Fan the braid.
- Push connector body under the braid.
- Slide the ferrule on the braid (in direction F)

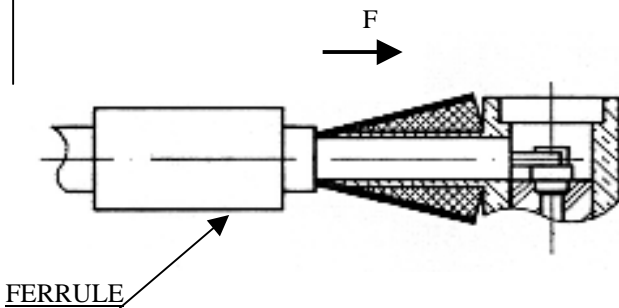

4

- Place insulator into body.
- Place and solder the cap.

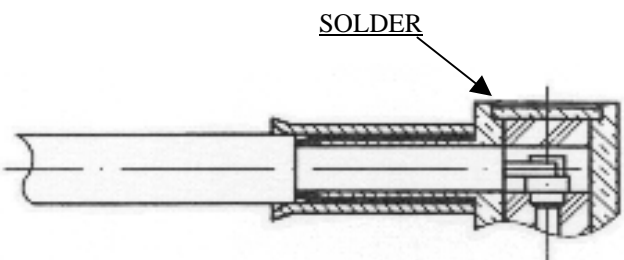

Issue : 0048 B

In the effort to improve our products, we reserve the right to make changes judged to be necessary.

